

# 100 bar Optical Level Control Unit TK3



## MAIN FEATURES

- **High reliability** ensured by absence of mechanical moving parts.
- **Sight glass and electronic LEDs** can be checked **on the same side** where is **more comfortable** to do **inspections**.
- Well consolidated steel with fused glass technology and the absence of seals ensures **no leakage** and **good chemical compatibility**.
- **Direct mounting onto 3/4 bolts compressors**
- **Easy maintenance of the coil** of the valve and of the **Electro-Optic sensor** that can be easily replaced **without emptying or depressurizing the plant**.
- **No need to use external pressure reduction devices**
- **Maximum compatibility with particular media** due to the possibility of mounting of different/custom valves
- 230 VAC /2A alarm relay output suitable for **direct connection in the security chain** of the system
- **Adapters suitable for various types of compressors**
- **Unit conform to directives:**

\*2004-108-CE

\*CEI EN 60204-1:2006



## Application Description

The TK3 is designed to control the oil level in the compressor crankcase in order to avoid the compressor to run without oil and so improve its lifetime. TK3 monitors the oil level with the embedded electro-optic sensor and comprises a solenoid valve for oil filling and a relay output contact to give an alarm or directly stop the compressor (through a separate power relay).

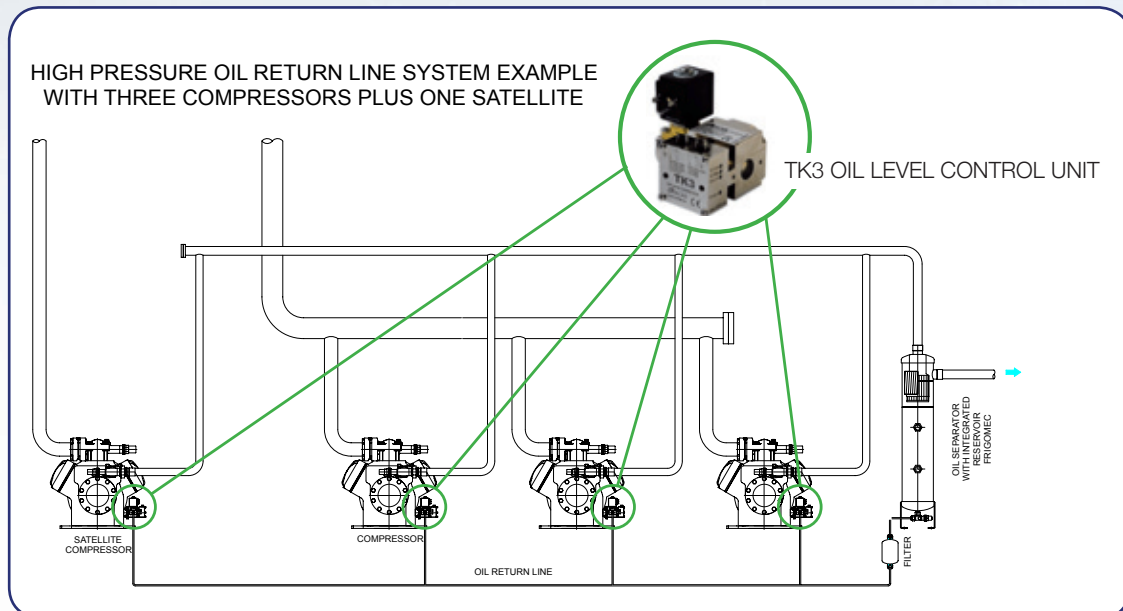

### Some other advantages of this solution:

- The TK3 is suitable to work with all the  $\Delta P$  of the system so there is no need to use pressure reduction components.
- Reduction of the number of junctions in the circuit with less possibility of having leakages.
- Usage of less components (simplified circuit and easier warehouse management).
- Simplified Installation (cost savings in terms of installation time).
- No need for calibrations on the field.

# 100 bar Optical Level Control Unit TK3

## Technical Data

<b>SUPPLY VOLTAGE</b>	24 VAC $\pm$ 10% @ 50
<b>SUPPLY CURRENT</b>	Each TK3 require 45VA (with supplied solenoid valve).
<b>ELECTRICAL CONNECTION</b>	9.4mm Industry Standard Connectors / EN175301-803A Connector
<b>OUTPUT SIGNAL</b>	Contact free relay output NO and NC
<b>RELAY OUTPUTS</b>	Up to 230VAC @2A The Normally Open (NO) alarm contact (blue wire) is closed when power is applied to the TK3
<b>HOUSING MATERIAL</b>	Nickel plated steel
<b>ENCLOSURE PROTECTION CLASS</b>	IP 65
<b>MEDIA TEMPERATURE</b>	-40°C÷+85°C
<b>AMBIENT TEMPERATURE</b>	-40°C÷+60°C
<b>MAX WORKING PRESSURE</b>	100 bar
<b>MOPD</b>	90 bar
<b>OIL RETURN LINE</b>	7/16 – 20 UNEF male
<b>CABLE TYPE</b>	PVC cable CEI 20-22. Working temp.: -20 ÷ +70 °C (fixed laying)

## Mechanical Dimensions

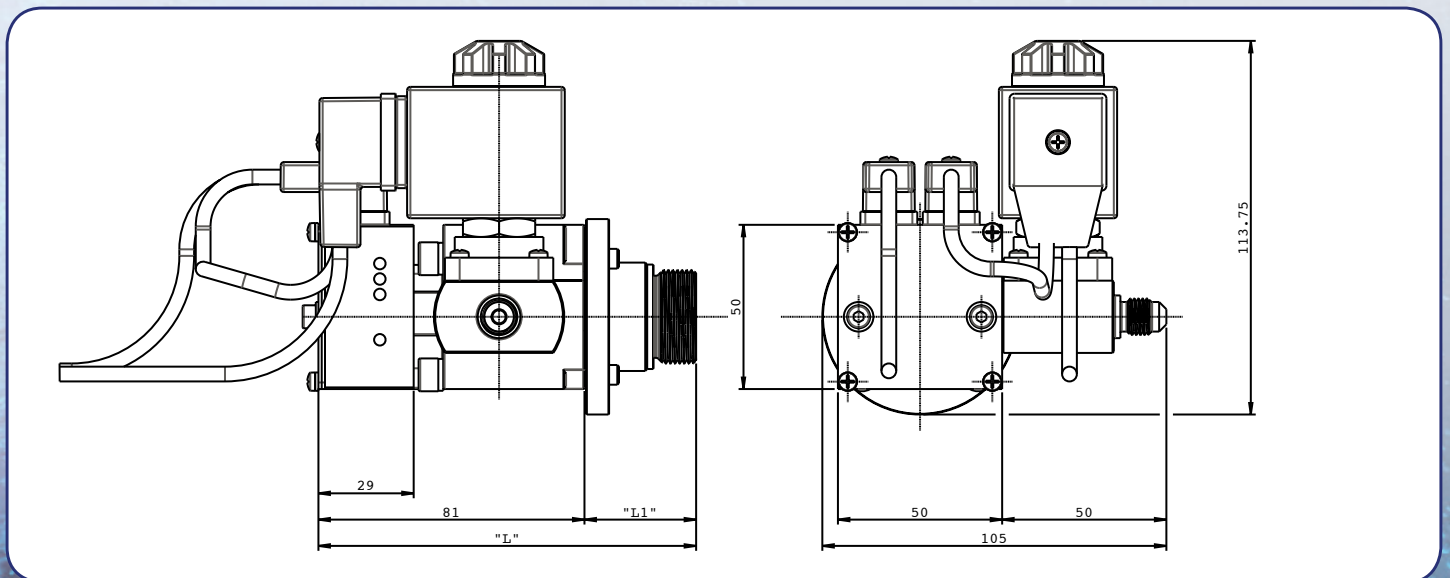

Note. - Quotes in mm -. L and L1 can vary depending on the adapter (see TK3 Adapters Addendum)



Via Emilia Ovest, 1179 - 41123 Modena - Italy  
Tel. +39 059 375498 - Fax +39 059 376294  
info@teklab.biz - www.inrefrigeration.com

